



ASSEMBLY INSTRUCTION

GRANDVUE 3 SEATER

ITEM CODE 66707

Imported by Amart Furniture Pty Ltd, Qld, Brisbane Australia.

For any assistance with assembly or for missing parts please phone

Amart Furniture, Customer Service Free call 1800 351 084

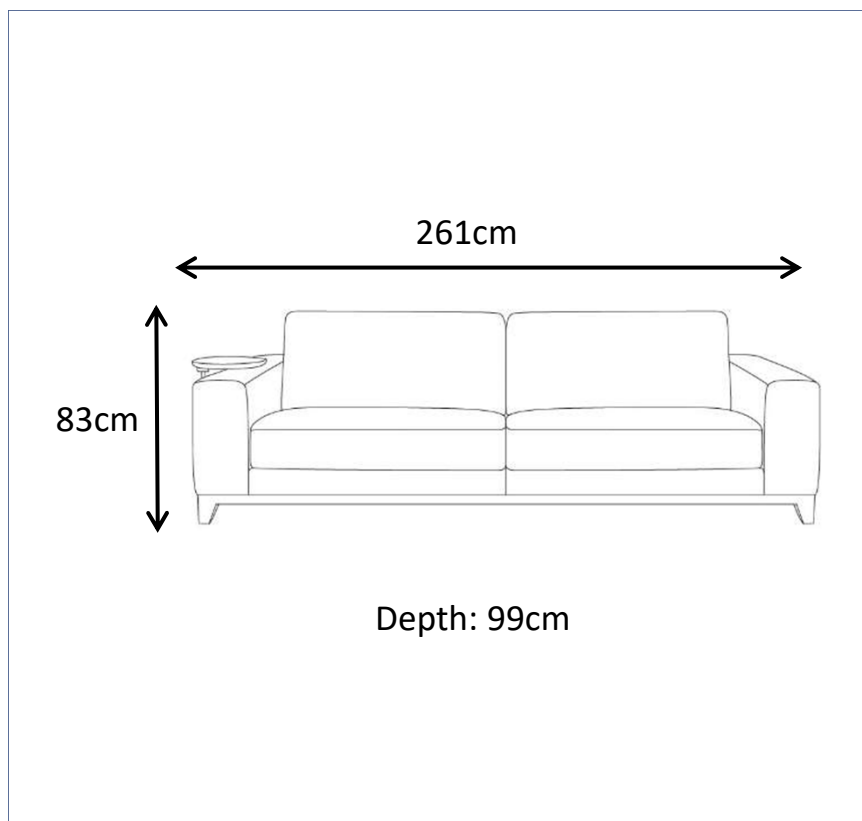

Imported by Amart Furniture Pty Ltd, Qld, Brisbane Australia.



For any assistance with assembly or for missing parts please phone

Amart Furniture, Customer Service Free call 1800 351 084

PRE-ASSEMBLY PREPARATION

Before you start:





1. Choose a clean, level, spacious assembly area. Avoid hard surfaces that may damage the product
2. Take care when lifting. Product should be assembled as near as possible to the point of use
3. Ensure that you have all required contents for complete assembly
4. Always read the assembly instructions carefully before beginning assembly.
5. Keep all hardware parts and packaging out of reach of small children.
6. Do not over tighten the screws and bolts as this may damage the threads

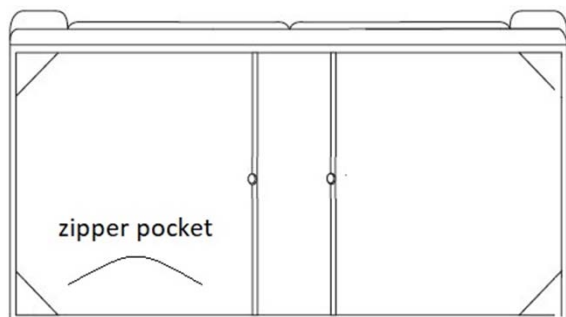

	
ALLOW 15 MINUTES	PEOPLE REQUIRED
ADDITIONAL TOOLS REQUIRED	

STEP 1: Locate package of sofa legs and package of table lid that are placed into the zipper pocket underneath.

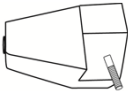
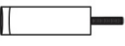

 With 2 people carefully turn onto back on piece of cardboard or carpet to protect covering

hexagon wrench 17mm  1pcs	hexagon nut M10  4pcs	flat washer $\varnothing 10 \times 1.5$  4pcs	spring washer $\varnothing 10$  4pcs
---	---	---	--

side leg  4pcs	middle leg  2pcs	table lid  1pcs
--	--	---

STEP 2: Make the screw of side leg go into hole at corner of bottom frame, then place flat washer, spring washer and hexagon nut on the screw in turn, finally use hexagon wrench to fasten hexagon nut tightly.

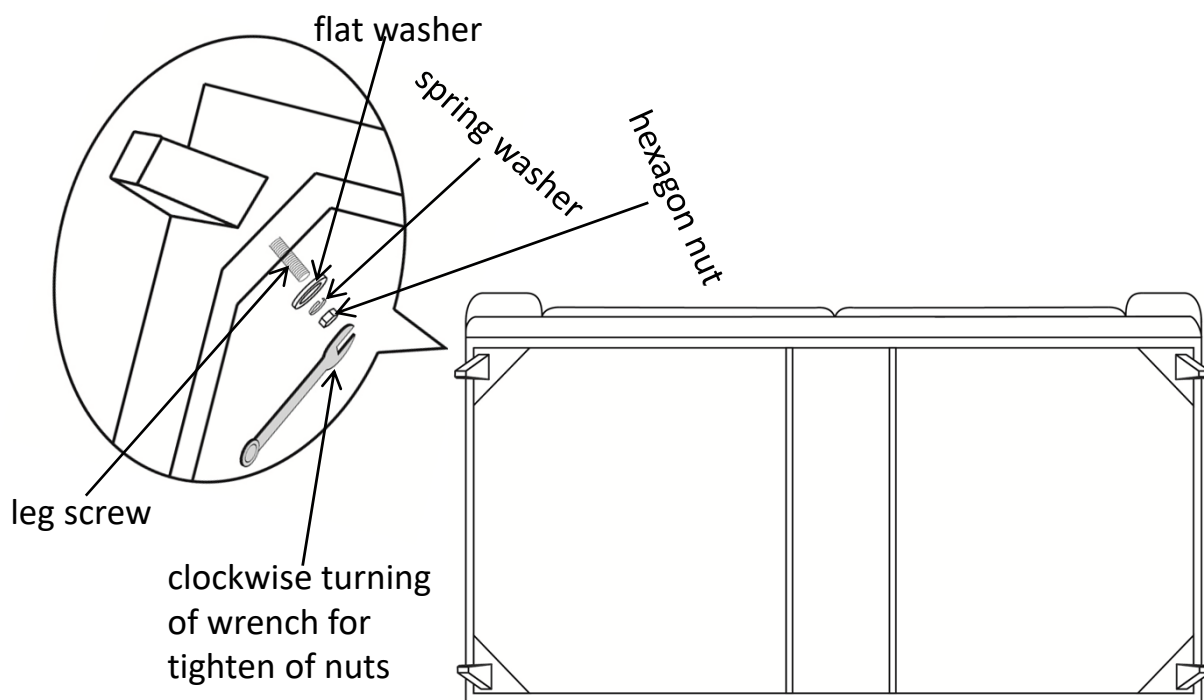

STEP 3: Screw two middle legs into holes in the central area of the bottom.

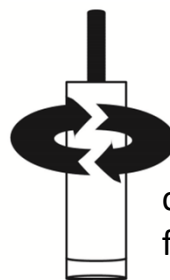
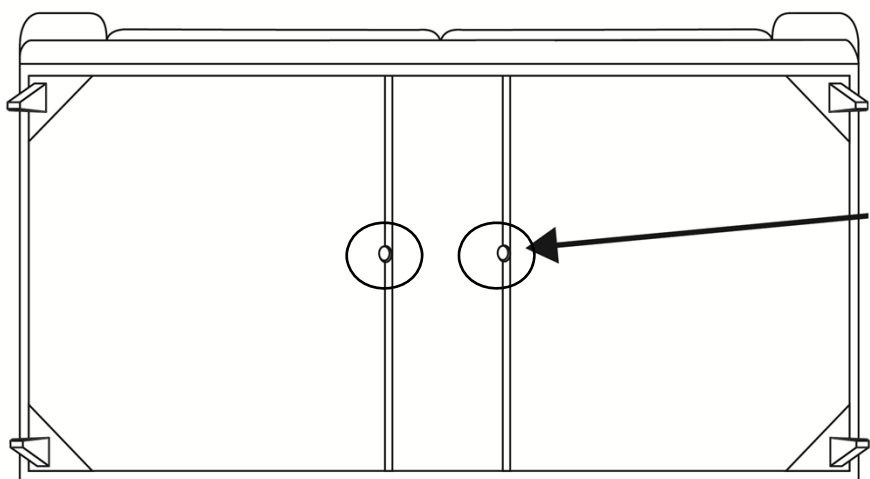

clockwise turning
for tighten of
middle leg with
screw

STEP 4: Take out the bracket of arm table with fittings from separate package dispatched together with every piece of sofa.

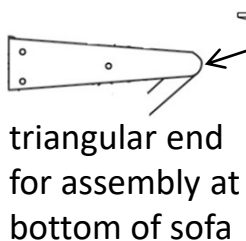

triangular end
for assembly at
bottom of sofa

fanned end
for assembly
of table lid

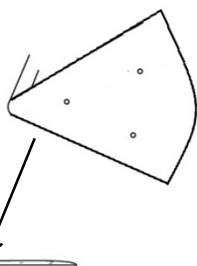

a. 3*Bolt M6X20



b. 3*Bolt M6X50

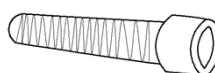

c. 1*Allen Key M5

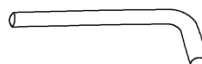

STEP 5: Use Allen key to fix table lid onto fanned end of bracket with three bolts M6X20.

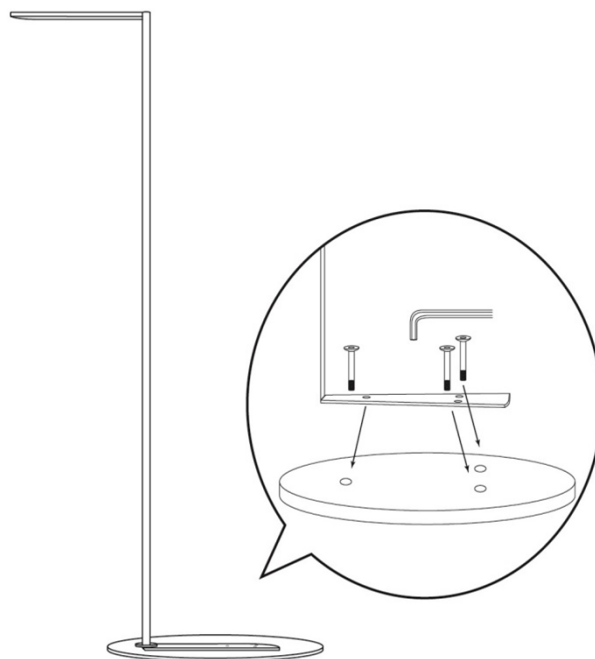

clockwise turning
of Allen key for
tighten of bolts

STEP 6: Use Allen key to fix the bracket to timber block at bottom of sofa with three bolts M6X50.

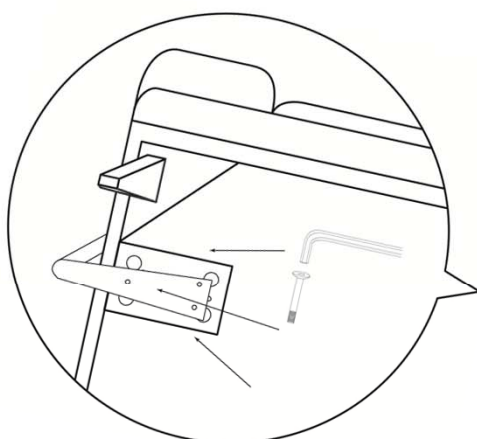

clockwise turning
of Allen key for
tighten of bolts

Note: The timber block has
been fitted to both the left
and right side so that the
table may be attached to
either side, as required.

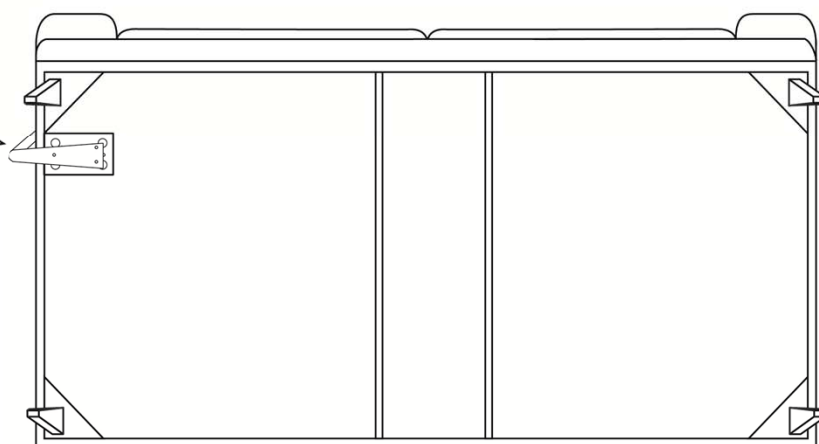

ASSEMBLY IS COMPLETE

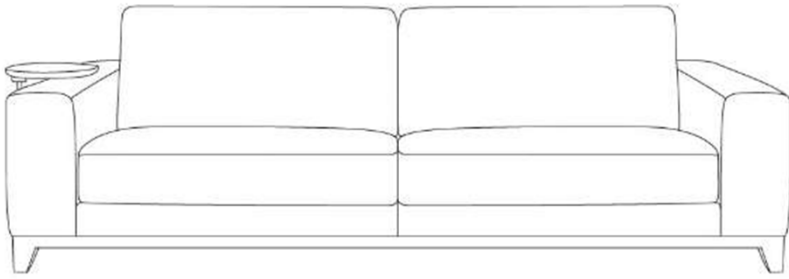

CARE AND MAINTENANCE

FABRIC CARE

REGULAR CARE: PROTECT FROM DIRECT SUNLIGHT.
VACUUM REGULARLY USING LOW SUCTION.
ROTATE REVERSIBLE CUSHIONS REGULARLY.

CLEANING:

DO NOT REMOVE CUSHION COVERS FOR SEPARATE
CLEANING EVEN THOUGH THEY HAVE ZIPPERS.
DO NOT WASH
DO NOT DRY CLEAN
DO NOT SHAMPOO CLEAN
CLEAN WITH HOT-WATER EXTRACTION MACHINE.
(HOT) PROFESSIONAL CLEANING RECOMMENDED
DO NOT USE DISHWASHING OR LAUNDRY
DETERGENTS
USE ONLY UPHOLSTERY DETERGENTS
DO NOT WET FILLING
DRY IN SHADE AWAY FROM DIRECT HEAT AND
SUNLIGHT
ALLOW TO DRY THOROUGHLY BEFORE RE-USE

SPOT CLEANING:

DO NOT RUB
DO NOT SPOT CLEAN WITH ANY SOLVENT.
TREAT SPILLS AND STAINS AS SOON AS POSSIBLE.
GENTLY SCRAPE ANY SOIL OR MOP ANY LIQUID
FROM THE SURFACE OF THE FABRIC.
APPLY PROPRIETARY CLEANING AGENTS STRICTLY
ACCORDING TO INSTRUCTIONS TO REMOVE THE
RESIDUE OF THE SPILL.
DO NOT SATURATE THE FABRIC OR INTERIOR WITH
WATER OR OTHER CLEANING LIQUIDS.

WARNING: APPLY ONLY WATER-BASED SOIL RESIST
(FABRIC PROTECTION) TREATMENTS. DO NOT USE
AEROSOL PRODUCTS.